

INSTRUCTION MANUAL

4. THE COLLET CHUCK OPTIONS

H041 APPLICABLE COLLET CHUCKS

SHANK DIA.	φ 1.0	φ 1.2	φ 1.4	φ 1.6	φ 1.8	φ 2.0	φ 2.34	φ 3.0	φ 3.175
CODE NO.	KP-050	KP-051	KP-007	KP-005	KP-052	KP-031	KP-036	KP-032	KP-033

5. MAINTENANCE

- The chips and dust may collect in the collet chuck. Clean it by taking out the collet chuck from the handpiece.
- When the handpiece gets dirt, wipe out with cloth moistened with lukewarm water or detergent.

<When the collet release ring is too tight to turn>

If you turn the collet release ring to set as you happenly leave the collet chuck not completely screw in, the collet release ring is very tight to turn. In that case, follow the steps below.

- 1) Loosen the “a” part (see the fig. on the right) by hands (just one or two turns). When it too hard to turn, wear a rubber glove for not to slip.
- 2) Then, turn the collet release ring to “R” position till it locks at the position.
- 3) Tighten back the “a” part, and insert the test rod into the collet, then, screw the collet chuck thoroughly by the V-spanner
- 4) Finally, turn the collet release ring to “S” position.

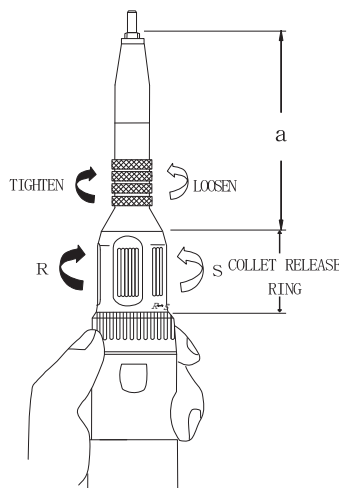

6. TROUBLE SHOOTING

☆ THE MOTOR DOES NOT OPERATE.

- CHECK IF THE AC CABLE IS CERTAINLY PLUGGED IN.
- CHECK IF THE FUSE OF THE POWER PACK IS BURNED OUT.
- CHECK IF THE CURLED CORD IS CERTAINLY CONNECTED.
- CHECK IF THE CARBON BRUSH OF THE MOTOR IS WORN OUT.
- CHECK IF THE COLLET RELEASE LEVER IS IN “SET” POSITION.

☆ THE REMOTE SWITCH DOES NOT OPERATE.

- CHECK IF THE FOOT SWITCH IS CONNECTED TO THE POWER PACK.
- CHECK IF THE POWER PACK IS EITHER MINIMO 1 SERIES OR 7 SERIES.

H041

LONG SLENDER HEAD

READ FOLLOWING INSTRUCTIONS THOROUGHLY BEFORE ATTEMPTING TO USE. KEEP THIS MANUAL ALWAYS IN THE VICINITY OF USE FOR YOUR REFERENCE. BEFORE USING THE UNIT, CHECK IF THERE ARE ANY DAMAGES ON THE UNIT DUE TO TRANSPORT CONDITIONS. IF ANY DAMAGES ARE FOUND, CONTACT OUR MINIMO DEALER.

SAFETY PRECAUTIONS

⚠ WARNING (INDICATES THAT INCORRECT OPERATION PRESENTS SIGNIFICANT DANGER OF ACCIDENT RESULTING IN DEATH OR SERIOUS INJURY TO THE USER.)

- DO NOT START TO RUN THE HANDPIECE WHILE ITS COLLECT CHUCK OPENS. FAILURE TO DO SO COULD CAUSE THE MOTOR TO BE OVERHEATED, RESULTING IN FIRE OR FAILURE.
- MAKE SURE WHETHER OR NOT THE HANDPIECE RUNS AFTER SWITCHING ON. IF THE HANDPIECE DOES NOT RUN AFTER SWITCHING ON, STOP USING IT. FAILURE TO DO SO COULD CAUSE THE MOTOR TO BE OVERHEATED, RESULTING IN FIRE OR FAILURE.
- WEAR AN APPROPRIATE EYE PROTECTION AND A DUST PROTECTING MASK WHEN USING THE HANDPIECE.
- TURN OFF THE MAIN SWITCH IMMEDIATELY AND UNPLUG THE AC CABLE WHEN ONE OR MORE OF THE FOLLOWINGS ARE RECOGNIZED. SMOKING; NASTY SMELL; STRANGE NOISE.
- DO NOT DISASSEMBLE AND REMODEL THE UNIT. ANY ACCIDENT OR MALFUNCTION CAUSED BY DISASSEMBLING AND/OR REMODELING WILL NOT BE COVERED BY OUR RESPONSIBILITY.
- NEVER PUSH THE SENTAN TOOL HARD ONTO THE WORKPIECE. EXCESSIVE FORCE ON THE TOOL WILL CAUSE DAMAGE TO THE TOOL AND ALSO REDUCE THE POWER OF THE MOTOR.
- WHEN TURNING ON THE POWER SWITCH, HOLD THE HANDPIECE FIRMLY.
- DO NOT TOUCH ANY REVOLVING BODIES SUCH AS SENTAN TOOL AND COLLET CHUCK.

⚠ CAUTION (INDICATES THAT INCORRECT OPERATION PRESENTS POSSIBILITY OF INJURY TO THE USER OR DAMAGE TO THE UNIT.)

- DO NOT USE THE UNIT IN EXCESSIVELY HUMID PLACE. THE CONDENSATION OF VAPOR ON AND/OR INSIDE OF THE UNIT CAUSES A MALFUNCTION OF THE UNIT, A SHORT CIRCUIT, FIRE OR AN ELECTRIC SHOCK
- DO NOT USE THE UNIT WHERE CORROSIVE GASES AND CHEMICALS POSSIBLY EXIST.
- THE AMBIENT TEMPARATURE SHOULD BE IN THE RANGE OF 0° ~ 40° C
- KEEP THE UNIT AWAY FROM CHILDREN.
- AVOID ANY HEAVY IMPACT TO THE UNIT. DO NOT DROP!
- KEEP ALL LIQUIDS SUCH AS OIL, WATER, AND ETC. OFF THE UNIT. THIS MAY CAUSE A MALFUNCTION OF THE UNIT, CATCH FIRE AND/OR GET AN ELECTRIC SHOCK.
- READ THE INSTRUCTION MANUAL OF THE MOTOR AND THE POWER PACK AS WELL.

MINITOR CO., LTD. JAPAN

21-1 Ryogoku 3-chome, Sumida-ku, Tokyo 130-0026 JAPAN
Phone +81 3 (6630) 5800 FAX +81 3 (6630) 5795

THE THINNEST POSSIBLE TIP. IDEAL FOR HARD TO REACH AREAS WITH REACH SIZE $\phi 12 \times 72\text{mm}$.

1. SPECIFICATION-STANDARD ACCESSARIES

(The accessories are subject to change without any notice)

- ◇ RATED SPEED : 40,000min⁻¹
- ◇ RATED WHEEL DIAMETER : $\Phi 30$
- ◇ APLICABLE MOTORS :
KV212H,KM112H,KM212H,
KV212,KM112,KM212,KM212L,KM112G
- ◇ SLEEVE COLLET $\phi 2.34$ (PA2001) 1pc.
- ※ENABLE TO USE TOOL WITH $\phi 2.34$ SHAFT WITHOUT CHANGING TO COLLET CHUCK $\phi 3.0$.
THE COLLET CHUCK $\phi 3.0$ (KP-032) IS MOUNTED.
- ◇ V-SHAPED SPANNER(KP-609A) 1pc.
- ◇ JOINT SHAFT HOLD PLATE(KP-M01) 1pc.

2. NAMES OF PARTS

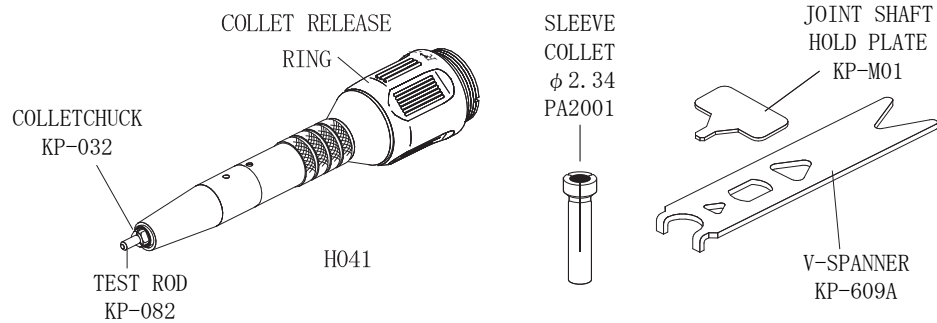

3. INSTALLATION

3-1. ATTACHING TO THE MOTOR

⚠ FOR YOUR SAFETY, DO NOT CONNECT THE MOTOR TO THE POWER PACK WHEN ATTACHING OR DETACHING THE HEAD TO THE MOTOR.

- 1) INSERT THE H011 HEAD ONTO THE MOTOR WITH PLACING THE CLAW OF THE HEAD IN A GROOVE OF THE MOTOR.
 - 2) TIGHTEN THE JOINT RING TO SECURE THE HEAD IN POSITION.
- * 4 GROOVES ARE PROVIDED ON THE MOTOR SO THAT YOU CAN CHOOSE A SUITABLE REMOTE SWITCH POSITION IN ACCORDANCE WITH YOUR OPERATION CONDITIONS.

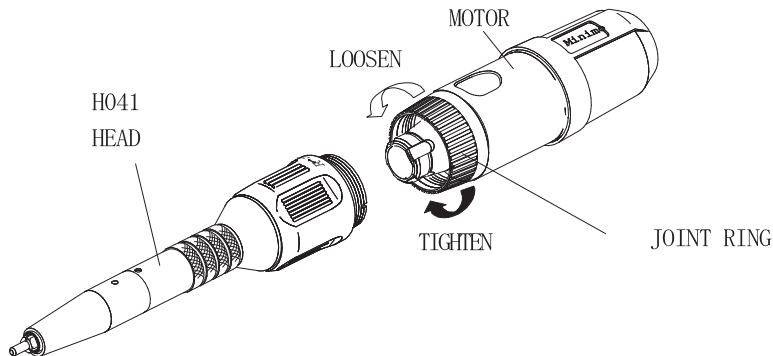

3-2. CHANGING THE SENTAN TOOLS

⚠ ALWAYS KEEP THE POWER OFF WHEN CHANGING THE TOOLS.
NEVER TURN THE COLLET RELEASE LEVER WHEN THE MOTOR ROTATING.

- 1) HOLD THE MOTOR AND TURN THE COLLET RELEASE RING TO THE RIGHT (RELEASE) TILL IT LOCKS IN THE POSITION.
 - 2) PULL OUT THE TEST ROD OR SENTAN TOOL AND INSERT THE SENTAN TOOL SUITABLE TO THE WORK. THEN, TURN THE COLLET RELEASE RING BACK TO THE LEFT (SET) TILL IT LOCKS IN THE POSITION.
 - 3) MAKE SURE THE TOOL IS SET FIRMLY BEFORE STARTING THE MOTOR.
- ※ THE H011 HEAD IS SHIPPED WITH A TEST ROD TO PROTECT THE COLLET. CHANGE IT TO THE SENTAN TOOL SUITABLE TO YOUR WORK.
- ◆ THE MOTOR WILL NOT ROTATE IF THE COLLET RELEASE RING IS IN THE RELEASE POSITION.

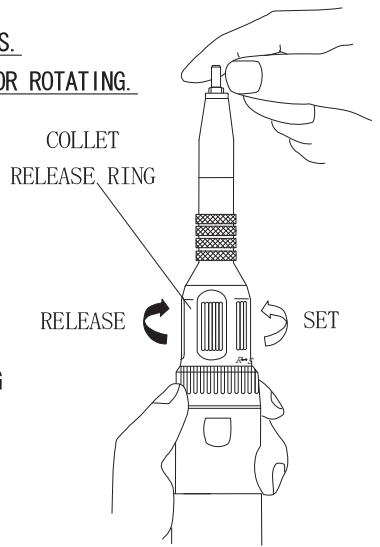

3-3. CHANGING THE COLLET CHUCK

- 1) TAKE OUT THE SENTAN TOOL.
- 2) KEEP THE COLLET RELEASE LEVER IN "RELEASE" POSITION AND INSERT THE TEST ROD.
- 3) TURN THE COLLET CHUCK BY THE V-SPANNER TO LOOSEN.
- 4) IF THE COLLET CHUCK CANNOT BE LOOSENED, TAKE THE MOTOR APART, AND INSERT THE JOINT SHAFT HOLD PLATE INTO THE CROSS CUT HOLE AT THE BOTTOM OF THE CLAMP HEAD.
- 5) HOLDING THE SHAFT WITH THE PLATE, HOOK THE V-SPANNER TO THE COLLET CHUCK AND LOOSEN IT.
- 6) PULL OUT THE COLLET CHUCK AND SCREW IN THE NEW COLLET CHUCK. THE TEST ROD IS INSERTED INTO THE NEW COLLET CHUCK PROTERCTING THE CHUCK TO TIGHTEN THE COLLET CHUCK WITH V-SPANNER.

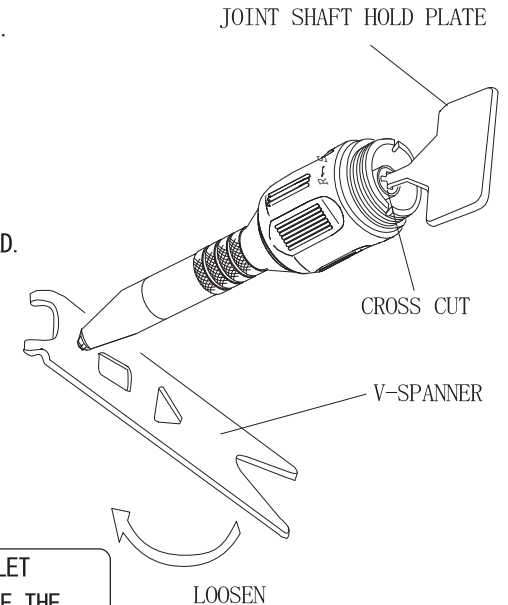

⚠ WHEN LOOSENING AND TIGHTENING THE COLLET CHUCK WITH THE V-SPANNER, ALWAYS PLACE THE TEST ROD IN THE COLLET CHUCK TO PROTECT THE COLLET FROM TWISTED OR BROKEN.