

Minimo[®]

POWER PACK

C2013/C2113/C2213

OPERATION MANUAL

MINITOR CO., LTD. JAPAN

21-1 Ryogoku 3-chome, Sumida-ku, Tokyo 130-0026 JAPAN

Phone +81 3 (6630) 5800 FAX +81 3 (6630) 5795

Introduction

Thank you for purchasing Minimo ONE Series Ver. 3 D.C. Power Pack.

This product is a Power Pack for Minitor's micro grinder Minimo handpieces.

Read this manual carefully for your safety prior to use.



Along with this manual, read manuals of handpieces (Standard / Slender Rotary, ANGLON, RECIPRON, Mini Belt Sander) carefully for your understanding of each function. Keep this manual in place reach to easily. Download this manual from our website if lost.

Precautions

This manual indicates symbols and signal words intending to avoid dangerous operation and handling for potential hazards and accident that could result in personal injury or damage to the product. For your safety use, read this manual and manuals of handpiece and foot switch before use. Keep this manual in place any operator can reach to easily and whenever refer to.



■ Symbols











The symbols on this manual indicate as following:







 Operation must be done.	 Operation is prohibited.
---	--





















■ Warning and Caution

Possible hazards and damages by wrong handling are classified as Warning and Caution in accordance with seriousness of risk.

 Warning Operation causing of significant and dangerous accident possibly resulting in death or serious injury.	 Caution Operation possibly causing of injury or physical damage on the product.
---	---

 Warning	
■ AC cord must be connected to grounded outlet. ○ May cause of electric shock, electrostatic hazard, communication failure, noise, etc. in case not grounded.	
■ Replace to new one (optional) if the AC cord was damaged. ○ May cause of fire and / or electric shock.	
■ Do not plug in and out with wet hands. ○ May cause of electric shock.	
■ Keep turning off this product when connecting handpiece to this product. ○ May cause of fire, electric shock and / or malfunction.	
■ Do not use damaged AC cord. ○ May cause of fire, electric shock and / or malfunction.	
■ Communication spark may occur while motor is rotating. Do not use the products near inflammable and explosive material such as thinner and gasoline. ○ May cause of fire and / or malfunction.	
■ Prevent this product from cutting oil, water, oil mist, etc. ○ May cause of fire, electric shock and / or malfunction.	
■ Do not use this product with any input voltage except instructed one. ○ May cause of fire and / or electric shock.	
■ Wear protective glasses for eye protection and respirator to prevent from dust. ○ May cause of unexpected damage due to chip and dust.	

 Warning	
■ Do not press On button on DC MOTOR selector and hand selector while collet chuck is in open. ○ Motor may be overheated by energization in condition that motor is locked and may cause of fire and / or malfunction.	
■ Confirm if handpiece works properly after turning DC MOTOR selector or hand selector on. ○ May cause of fire and / or electric shock by overheating motor in case motor was not working. Cause motor does not work: collet chuck in open, malfunction of handpiece, motor or power pack, etc.	
■ In case abnormal noise, smoke and / or bad smell occurred, turn power switch off and unplug AC power cord. ○ May cause of fire and / or electric shock.	
■ Do not disassemble and / or remodel. ○ May cause of fire, electric shock and / or malfunction. ○ May cause of significant influence on safety and performance.	
■ Ask us for repairing. ○ May cause of fire, electric shock and / or malfunction. ○ May cause of significant influence on safety and performance.	

 Caution	
■ Do not disassemble and assemble this product. ○ May cause of damage and / or malfunction.	
■ Do not pull cord when pulling out plug of AC power cord. ○ May cause of fire, electric shock and / or malfunction due to damage on cord.	
■ Do not put heavy material on AC power cord. ○ May cause of fire, electric shock and / or malfunction due to damage on cord.	
■ Keep AC power cord away from thermal appliance. ○ May cause of fire, electric shock and / or malfunction.	
■ Use this product in condition without condensation. ○ May cause of fire, electric shock and / or malfunction.	
■ Use this product within temperature from 0°C to 40°C. ○ May cause of damage and / or malfunction.	
■ Do not use this product near device generating electric noise unusually. ○ May cause of damage and / or malfunction.	
■ Unplug the power cord for your safety while cleaning. ○ May cause of electric shock and / or malfunction.	
■ Do not drop and / or hit this product. ○ May cause of damage and / or malfunction.	
■ Do not use this product under environment generating corrosive gas (chlorine gas, hydrogen sulfide, sulfurous acid gas, etc.). ○ May cause of fire, electric shock and / or malfunction.	
■ Follow the instruction of your local government for disposing this product.	
■ Keep this product away from children.	
■ Turn power switch off and unplug AC power cord for your safety while leaving a workshop	
■ Prevent dust, oil, water, etc. from entering inside. If liquid and / or foreign substances entered, turn power switch off, unplug AC power cord and ask us for repairing. ○ May cause of fire, electric shock and / or malfunction.	
■ Unplug AC power cord for your safety while replacing carbon brushes and other parts. ○ May cause of electric shock and / or malfunction.	
■ Unplug AC power cord for your safety while replacing fuse. Specified fuse must be used. ○ May cause of electric shock and / or malfunction.	
■ Do not connect any other motor and handpiece than Minitor products. ○ May cause of malfunction and / or failure.	
■ Do not put anything on power pack. ○ May cause of damage and / or malfunction.	
■ Use both hands when carrying power pack. ○ Holding by one hand may cause of damage and / or malfunction by dropping.	

Contents

- Introduction 1
- Precautions 1 ~ 2
- Contents 3
- 1. Components 3
- 2. Features 4
- 3. Specifications 5
- 4. Names and Functions 5 ~ 6
- 5. Operations 7
 - 5-1 How to Use without Foot Switch
 - 5-2 How to Use without Foot Switch (FS202, VC302)
- 6. Error Indication and Troubleshooting 8
- 7. Supplementary Description of External I/O Signal 9 ~ 13
 - 7-1 In Case of Turning Motor On / Off Only Controlled by External Signal (FS Mode)
 - 7-2 In Case of Turning Motor On / Off and Rotation Speed of Motor Controlled by External Signal (VC Mode)
 - 7-3 In Case of Controlling All Functions of Power Pack by External Signal (Auto Mode)
 - 7-4 Supplementary Description of External I/O Signal
- 8. Optional Accessory 14
- 9. Before Asking for Repairing 14
- 10. Maintenance 14

1. Components

Check all items inside.

Power Pack 1 piece
 ◆C2013 ◆C2113 ◆C2213
 (Any one)



Fig. 1

AC Power Cord 1 piece

- ◆CA10 (100VAC)
- ◆CA11 (115VAC)
- ◆CA12 (230VAC)
- (Any one)



Rubber Cradle 1 piece

- ◆RM11



Fig. 2

Fuse 1 piece

- ◆PFU-2.0A (C2013/C2113)
- ◆PFU-1.0A (C2213)



Operation Manual

- ◆IMW-C2013

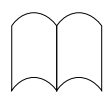

Fig. 3

【Motors capable of connecting to this product other than Ver. 3's】

The following motors and handpieces in former series can be used with this product.

- Minimo ONE Series (1997 - 2013)
 - KV11H, KV21H, KM11H, KM21H, KV21, KM11, KM21, KM21L, KM11G, BS31, RE11, RE21
- Minimo ONE Series Ver. 2 (2013 -)
 - KV112H, KV212H, KM112H, KM212H, KV212, KM112, KM212, KM212L, KM112G, BS312, RE112, RE212

⚠ Caution ■ Hold bottom of power pack by both hands when carrying. Holding by one hand may cause of damage and / or malfunction by dropping.

■ Compatibility Table of Power Pack, Motor and Head

Table 1

Power Pack	Motor				Head								Clamp Head			Joint	
	One Series	Ver. 2	Ver. 3	Max Speed [min ⁻¹]	H011	H021	H033	H041	H211	H221	H231	H311	MX52	MX53	FX91	ET51	MG03
					Standard	Slender	Heavy Duty	Long Slender	Standard	Heavy Duty	Variable amp 1.1 Type	Standard					
C2013 C2113 C2213	KV11H	KV112H	-	50,000	○	○							○				
	KV21H	KV212H	-	40,000	○	○											
	KM11H	KM112H	-	35,000	○	○										○	
	KM21H	KM212H	-	30,000	○	○	○							○	○	○	○
	KV21	KV212	-	25,000	○	○										○	○
	KM11	KM112	-	20,000	○	○	○							○	○	○	○
	KM21	KM212	-	15,000	○	○	○	○	○	○	○			○	○	○	○
	-	-	KK313	10,000	○	○	○	○	○	○	○			○	○	○	○
	KM21L	KM212L	-	8,000	○	○	○	○	○	○	○			○	○	○	○
	KM11G	KM112G	-	6,600	○	○	○	○	○	○	○			○	○	○	○

C2013 C2113 C2213	One Series	Ver. 2	Ver. 3	Min. Speed [min ⁻¹]	Load Amp [A]
	RE11	RE12	-	-	3,500
	RE21	RE22	-	-	7,000
	BS31	BS32	-	700	-

○ Compatible combination
 * Percentage of output level is indicated on digital display of power pack while connecting to RECIPRON and Mini Belt Sander.

2. Features

- **Microcomputer Control**
Motors can be optimum-controlled by microcomputer.
- **Motor Identification Function**
Motor can be identified by connection only and each motor is controlled optimally.
- **Two Lines of Output Terminal**
Two motors can be connected at the same time.
Two motors cannot be operated at the same time.
- **Feedback Circuit**
Feedback circuit leading maximum performance of motor is installed and makes better workability happen.
- **External I/O Signal Control**
Remote controlling is available by using external I/O signal through foot switch socket.
Enable to control Start / Stop, rotation speed, rotation direction, etc. by remote.
- **Digital Display**
Set rotation speed or rotation speed of motor is indicated.
- **Error Code Display Function**
Error of power pack and motor are indicated.
- **Load Meter**
Loaded condition of motor is indicated on LED.
- **Rotation Speed Maintaining Function (for using VC302)**
Rotation speed can be controlled by stepping-on amount and the rotation speed can be maintained temporarily.
See the rotation speed maintaining function on "5-2 How to Use without Foot Switch" for operation.
- **Quick Start Mode**
Enable to change to Quick Mode for shortening time to reach to set rotation speed.
 - ◆ Normal Mode (default): Approx. 2.6 seconds to the maximum speed
 - ◆ Quick Mode: Approx. 1.1 seconds to the maximum speed
- **Risk Avoidance Function by Overloading**
Overloading is applied to avoid risk in case of fixed loading, activating handpiece in condition that collet chuck is in open (motor-locked condition), etc.
 - ◆ Overloading in normal condition
 - Motor in working ⇒ Overload warning (5 sec.) ⇒ Overloading (suspended)
 - ◆ Overloading in motor-locked condition
 - Motor-locked condition ⇒ Motor activated ⇒ Overload warning (5 sec.) ⇒ Overloading (suspended)
 - ◆ Overloading in fixed loading condition
 - Fixed loading condition (15 sec.) ⇒ Overload warning (5 sec.) ⇒ Overloading (suspended)

3. Specifications

- Input Voltage : C2013 100VAC±5% 50/60Hz
C2113 115VAC±5% 50/60Hz
C2213 230VAC±5% 50/60Hz
- Power Consumption : Rated 45W
- Output Voltage : 1 - 30VDC (Rated 30V / 1A)
- Overloading Function : Overloading function is activated within 3 seconds in case output current exceeds over the range approx. 1.6 - 3A.
- Overheat Protection Function : Overheat protection function is activated when the temperature of internal heat sink exceeds 100°C.
- Operating Temperature and Humidity Requirement : 0 to 40°C, 20 to 80% (non-condensing)
- Dimensions : 110 (W) × 220 (D) × 110 (H) mm (excluding leg parts)
- Weight : Approx. 2.5 kg

4. Names and Functions

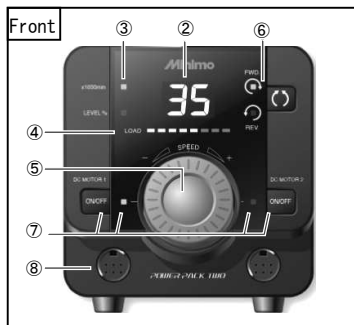

Fig. 4

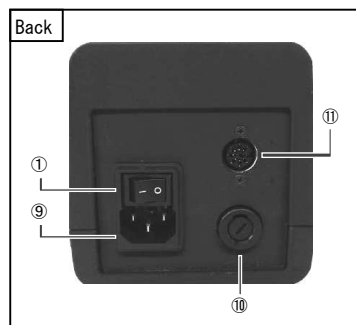
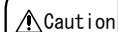

Fig. 5

- ① Power Switch
Power ON / OFF switch (I : ON O : OFF)
- ② Digital Display
Set rotation speed, rotation speed of motor, ratio in percentage to maximum rotation speed, error code when error occurred are indicated.
- In case of connecting to Minimo ONE Series Ver. 3 and Ver. 2 handpieces (except RECIPRON and Mini Belt Sander)
Motor in stop : Set rotation speed is indicated.
Motor in operation : actual rotation speed of motor is indicated.
 - In case of connecting to RECIPRON, Mini Belt Sander and former series handpieces
Motor in stop : Set rotation speed in percentage against maximum rotation speed is indicated (*1).
Motor in operation : actual rotation speed in percentage against maximum rotation speed is indicated.
- *1 ... 10 to 99 percents and FL, meaning of 100 percent, are indicated.
e.g. 1) In case that maximum rotation speed is 10,000 min⁻¹
Rotation speed when "30" indicated → 10,000 min⁻¹ × 0.3 = approx. 3,000 min⁻¹
Rotation speed when "FL" indicated → 10,000 min⁻¹ × 1.0 = approx. 10,000 min⁻¹
e.g. 2) In case of RECIPRON RE212
Stroke speed when "30" indicated → 7,000 times / min. × 0.3 = approx. 2,100 times / min.
e.g. 3) In case of Mini Belt Sander BS312
Belt speed when "30" indicated → 700 m / min. × 0.3 = approx. 210 m / min.
- ③ Rotation Speed / Output Rate Indicator
- ×1000 min⁻¹ Light
Turns on while rotation speed is indicated.
 - LEVEL % Light
Turns on while output rate is indicated.

- ④ Load Meter
LED turns on from left corresponding to loading condition (flowing electric current) of motor.
- Use motor within range of white LED indicating range of use.
 - Orange LED indicates overloading. Reduce the load for motor.
 - Red LED indicates excessive overloading. Avoid the load for motor immediately.
 - In case flowing electric current is reduced for 5 seconds, load meter turns off.
- ⑤ Speed Control Dial
Set rotation speed of motor.
- ⑥ Rotation Direction Switch / Rotation Switch Light
Set rotation direction of motor. / Either rotation switch light turns on depending on set of rotation direction.
- ◆ FWD. = Forward Rotation (Clockwise)
 - ◆ REV. = Reverse Rotation (Counterclockwise)



- Change rotation direction when motor is in stop.
- Do not use RECIPRON and Mini Belt Sander in REV. (reverse rotation direction).

- ⑦ DC MOTOR Selector / DC MOTOR Output Light
- ◆ DC MOTOR Selector is a switch to select terminal and turn motor on / off.
 - ◆ The color of DC MOTOR Output Light indicates following conditions:
"Lights out" Terminal is not selected.
"Green" Terminal is selected and motor is in stop.
"Orange" Motor is in operation.
"Red" (flashing) Error occurs.

- ⑧ DC MOTOR Connection Terminal
Terminal connecting to motor.

- ⑨ Power Cord Socket
Socket connecting to AC power cord.

- ⑩ Fuse Compartment
Compartment for fuse. Remove cover of fuse compartment by using flathead screwdriver.
Product Code of Fuse: For C2013 / C2113 : PFU-2.0A
For C2213 : PFU-1.0A



- Make sure to unplug AC power cord when replacing fuse.
- Make sure to use specified fuse for replacement.
- Ask us for repairing in case of damage by unknown cause such as short circuit by overcurrent.

- ⑪ Foot Switch Connection Terminal
Terminal connecting to foot switch (FS202, VC302 as optional accessories) and plug for remote control (RPG-8P as optional accessory).

5. Operations

5-1 How to Use without Foot Switch

- (1) Connect AC power cord to power cord socket and plug AC power cord into outlet.
- (2) Connect plug of motor to DC MOTOR connection terminal.
- (3) Turn speed control dial all the way to counterclockwise direction.
- (4) Turn power switch on.
- (5) In case DC MOTOR output light in use is off, press hand switch on motor or DC MOTOR selector to select DC MOTOR connection terminal. Selected DC MOTOR output light turns green.
- (6) Press rotation direction switch and select rotation direction (standard direction is FWD.).
- (7) Set rotation speed of motor by speed control dial.
- (8) Press hand switch on motor or DC MOTOR selector to start running motor.
- (9) Press hand switch on motor or DC MOTOR selector to stop running motor.



- Use motor within range of white LED indicating range of use.
- Use motor within maximum rotation speed set each Sentan Tool.
- Two motors cannot be run at the same time.

Set Quick Start Mode

Enable to change to Quick Mode for shortening time to reach to set rotation speed. Normal Mode (default) takes approx. 2.6 seconds to the maximum speed and Quick Mode takes approx. 1.1 seconds to the maximum speed.

Switch normal and quick mode by following procedure.

<Operations>

1. Turn power switch off.
2. Turn power switch on while pressing rotation direction switch and DC MOTOR 2 Selector at the same time.
3. As normal mode, "no" is indicated on digital display in condition of pressing rotation direction switch and DC MOTOR 2 Selector. In case "FA" is indicated on digital display, it is quick mode.
(Normal mode "no" and quick mode "FA" can be switched by turning power switch on and off repeatedly.)
4. Setting of start mode is saved by releasing rotation direction switch and DC MOTOR 2 Selector.
After saving start mode, setting of normal and quick mode remain even if power switch is off.

5-2 How to Use without Foot Switch (FS202, VC302)

- (1) Connect foot switch to foot switch connection terminal on back side of this product.
- (2) Follow step (1) to (7) of "5-1 How to Use without Foot Switch".
- (3) Turn on motor by stepping on foot switch.
- (4) Turn off motor by releasing foot from foot switch.
- (5) Cancel error by releasing foot from foot switch when error occurred. In case error number is 90 to 99, turn power switch off to cancel error.

<With ON / OFF Type Foot Switch (FS202)>

Only turning ON and OFF of motor can be switched.

Other operations and setting can be controlled on front panel of this product.

<With Variable Type Foot Switch (VC302)>

Set rotation speed of motor by speed control dial. Set rotation speed is the maximum rotation speed when stepping on foot switch.

Rotation speed of motor can be controlled corresponding to stepping-on amount.

◎Rotation Speed Maintaining Function (for using VC302)

Rotation speed can be fixed temporarily when pressing hand switch of motor or DC MOTOR selector of this product in use in condition of stepping on variable type foot switch.

In this condition, rotation speed is maintained even if stepping out of foot switch.

For releasing, step on the foot switch again or press hand switch of motor or DC MOTOR selector of this product in use.



- Do not plug in and out foot switch while power switch is on.
- Error is occurred and may cause of damage and / or malfunction.

6. Error Indication and Troubleshooting

- Error information is indicated on digital display in case error occurred.
- "E.-" indicating error occurred and abbreviation is displayed alternately.
(e.g. "E.-" and "oL" are displayed alternately when overloading occurred.)
- Abbreviation is switched to error number by pressing rotation direction switch while error is indicated.
(e.g. "E.-" and "16" are displayed alternately when overloading occurred.)
- How to release error.
 - Error can be released by pressing hand switch of motor or DC motor selector of this product.
 - In case using foot switch, error can be released by turning foot switch off.
 - In case error number is 90 to 99, error can be released by turning power switch off.

Table 2 Contents of Error and Troubleshooting

Error No.	Abbreviation	Cause of Error	Status	Troubleshooting
11	Po	Power Pack	Abnormal condition is detected in saved setting data.	Press DC motor selector of DC motor connection terminal in use or hand switch of motor.
12	Fo	Foot Switch	Motor signal of foot switch or external signal is on when turning power switch on.	Turn motor signal of foot switch or external signal off.
13	HP	Handpiece	Signal error of handpiece model.	Press DC motor selector of DC motor connection terminal in use. Connect plug of motor.
15	oL	Overload	Overloading by overcurrent to motor.	Press DC motor selector of DC motor connection terminal in use or hand switch of motor. Use motor within range of white LED indicating range of use.
17	oH	Heating	Overheating condition due to increasing temperature inside of power pack.	Press DC motor selector of DC motor connection terminal in use or hand switch of motor and wait for using motor until temperature inside power pack goes down. (*1)
19	Po	Power Pack	Too much voltage to motor.	Press DC motor selector of DC motor connection terminal in use or hand switch of motor. Use motor within range of white LED indicating range of use.
91	Fo	Foot Switch	Plug of foot switch is connected / disconnected.	Turn power switch off. In case using foot switch, connect plug of foot switch and turn power switch on.
92	Po	Power Pack	Output voltage is too low.	Ask for repairing.
93	Po	Power Pack	Output voltage is too high.	Turn power switch off. Turn power switch on. Ask for repairing in case same error occurred.
94	Po	Power Pack	Taking more than 10 seconds until motor stopped.	Turn power switch off. Drop rotation speed in case using heavy Sentan Tool. Turn power switch on. Ask for repairing in case same error occurred.
95	Po	Power Pack	High output current when motor is in stop.	Ask for repairing.
96	Po	Power Pack	Abnormal value in memory of power pack is detected.	Ask for repairing.
99	Po	Power Pack	Error on circuit is detected.	Ask for repairing.

(*1) In case of overheating, "oH" indicating overheating may be displayed because of high temperature inside even though error is released. "oH" is disappeared if temperature inside drops. Wait for using motor until "oH" disappears.

7. How to Use by External Signal

■The following operations can be controlled through foot switch connection terminal.

- Turning motor on / off
- Setting rotation speed
- Setting rotation direction
- Setting DC motor connection terminal in use
- Output of alarm signal

■Remote controlling by external signal has 3 modes: FS, VC and Auto mode.

Description and setting for each mode are described on Table 3 below.

Select mode and connect target pin inside plug for remote controlling and J (Jack).

Table 3

No	Mode	Description	Setting
1	FS Mode	Only operation of turning motor on / off can be controlled by external signal (rest of operations can be controlled on front panel).	Connect pin No. 1 and J
2	VC Mode	Operations of turning motor on / off and setting of rotation speed can be controlled by external signal (rest of operations can be controlled on front panel).	Connect pin No. 4 and J
3	Auto Mode	All operations can be controlled by external signal (no operation can be controlled on front panel).	Connect pin No. 8 and J

■Pin configuration of plug for remote controlling

View from pin side (Fig. 7)

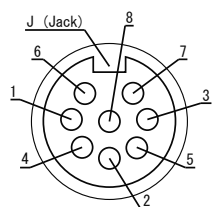

Fig. 6

Cylindrical metal part is J (Jack).
Plug for remote controlling RPG-8P (optional)



View from this side J (Jack)

Fig. 7

■Each of pin number, signal name and function of plug for remote controlling is described on Table 4 below.

Table 4

Pin No.	Signal	Function	Input / Output
1	Rotation direction	Switching rotation direction (FWD: open, REV: connect to pin No. 3)	Input
2	Rotation speed	Rotation speed is changed depending on input voltage. Rotation speed set by speed control dial is the maximum rotation speed. (Voltage +0.4V ~ +4V is added between pin and J. Rotation speed reaches to the maximum when input +4V. Maximum 12V)	Input
3	+12V power	Outputting +12V voltage (allowable electric current: 50mA or less. Use this power only for external signal)	Output
4	Switching DC motor connection terminal	Switching DC motor connection terminal 1 and 2. (DC Motor 1: open, DC Motor 2: connect to pin No. 3)	Input
5	Turning motor on / off	Turning motor on / off (On: connect to pin No. 3, Off: open)	Input
6	Alarm (Signal side)	Signal output as alarm signal when error occurred (photocoupler output)	Output
7	Alarm (Common side)	Normal condition: photocoupler output ON, Error condition: photocoupler output OFF	
8	Auto mode setting	Connect to J pin when all operations are controlled by external signal.	Input
J (Jack)	Ground (GND)	Ground for pin No. 3 (+12V power)	-



Caution

- Do not connect power prepared by user to pin No. 3. May cause of malfunction.
- Use motor within range of white LED indicating range of use on load meter.

■Circuit Diagram of External Signal in Power Pack

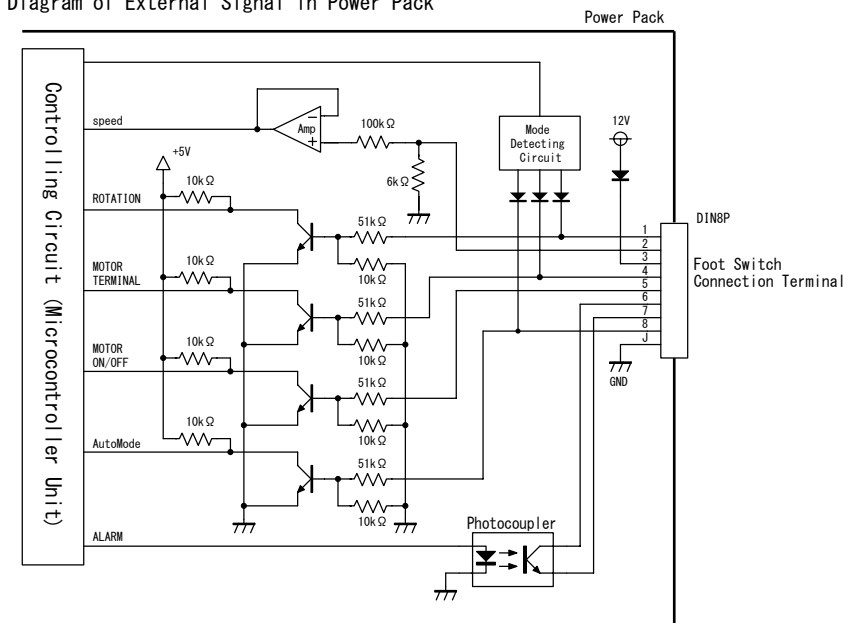

Fig. 8

7-1 In Case of Turning Motor On / Off Only Controlled by External Signal (FS Mode)

- ①Connect pin No. 1 of plug for remote controlling and J (Jack) inside plug (FS mode setting).
- ②Connect both ends of pin No. 3 and 5 and contact of switch, relay, etc.
- ③Motor is run by turning contact on.
- ④Motor is stopped by turning contact off.
- ⑤Error is released by turning contact off in case error occurred.
*Relay or relay output unit is recommended in case of controlling by sequencer, etc.

◎Example of Connection Diagram

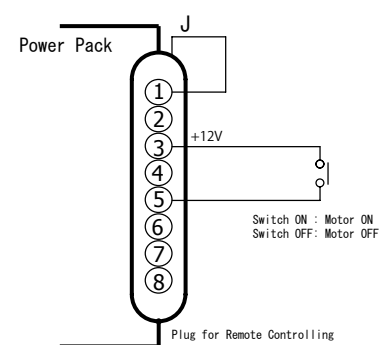

Fig. 9 In Case of Using Contact, etc. of Relay, etc.

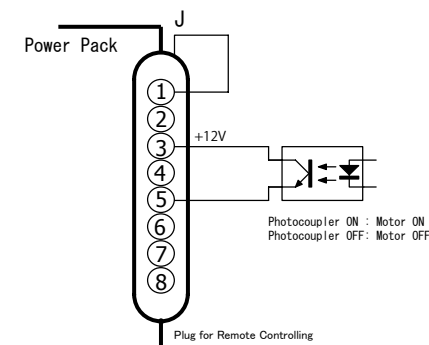

Fig. 10 In Case of Using Photocoupler

7-2 In Case of Turning Motor On / Off and Rotation Speed of Motor Controlled by External Signal (VC Mode)

- ① Connect pin No. 4 of plug for remote controlling and J (Jack) inside plug (VC mode setting).
- ② Connect both ends of pin No. 3 and 5 and contact of switch, relay, etc. for setting of rotation direction.
Contact ON: Motor ON Contact OFF: Motor OFF
- ③ Set maximum rotation speed by turning speed control dial.
- ④ Apply control voltage to both ends of pin No. 2 and J (Jack) for controlling rotation speed.

<Control Voltage>

- Pin No. 2: +0.4V - +4V (maximum voltage: +12V)
- Jack : GND

* Rotation speed set by speed control dial is the maximum rotation speed. Rotation speed of motor is controlled in accordance with applying voltage to pin No. 2.

e.g. In case of using motor with $50,000\text{min}^{-1}$ and setting $40,000\text{min}^{-1}$ by speed control dial

- Motor runs in $40,000\text{min}^{-1}$ by applying +4V to pin No. 2 (rotation speed is not exceed $40,000\text{min}^{-1}$ in spite of applying +4V or more).
- Motor runs in $10,000\text{min}^{-1}$ by applying +1V to pin No. 2.
- In case of making rotation speed $50,000\text{min}^{-1}$, set the maximum rotation speed to $50,000\text{min}^{-1}$ by speed control dial and apply +4V to pin No. 2.

◎Example of Connection Diagram

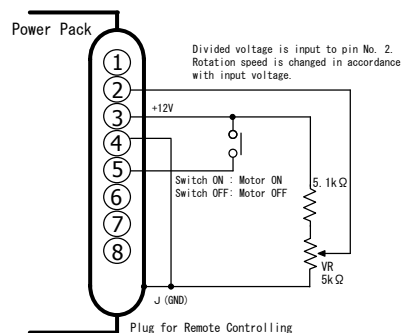

Fig. 11 In Case of Using Variable Resistor (VR) for Setting Rotation Speed

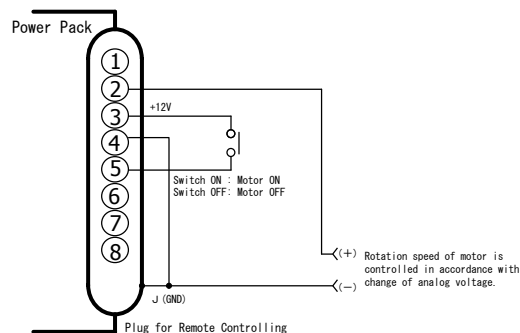

Fig. 12 In Case of Using Voltage Signal for Setting Rotation Speed

7-3 In Case of Controlling All Functions of Power Pack by External Signal (Auto Mode)

- ① Connect pin No. 8 of plug for remote controlling and J (Jack) inside of plug (Auto mode setting).
- ② Connect both ends of pin No. 3 and 1 and contact of switch, relay, etc. for setting of rotation direction.
Contact ON: REV. (Counterclockwise), Contact OFF: FWD. (Clockwise)
* Turn ON / OFF of motor on 100ms after setting rotation direction.
- ③ Connect both ends of pin No. 3 and 4 and contact of switch, relay, etc. for setting of DC motor connection terminal.
Contact ON: DC MOTOR 2, Contact OFF: DC MOTOR 1
* Turn ON / OFF of motor on 100ms after setting DC motor connection terminal.
- ④ Connect both ends of pin No. 3 and 5 and contact of switch, relay, etc. for turning motor on / off.
Contact ON: Motor ON, Contact OFF: Motor OFF
Error is released by turning contact off in case error occurred while motor is running.
* In case error number is 90 to 99, error can be released by turning power switch off.
- ⑤ Apply control voltage in between pin No. 2 and J (Jack) for controlling rotation speed.
Apply control voltage as following polarity.

<Control Voltage>

- Pin No. 2: +0.4V - +4V (maximum voltage: +12V)
- Jack: GND

* Rotation speed set by speed control dial is the maximum rotation speed and rotation speed of motor is controlled in accordance with applying voltage to pin No. 2.

e.g. In case of using motor with $50,000\text{min}^{-1}$ and setting $40,000\text{min}^{-1}$ by speed control dial

- Motor runs in $40,000\text{min}^{-1}$ by applying +4V to pin No. 2 (rotation speed is not exceed $40,000\text{min}^{-1}$ in spite of applying +4V or more).
- Motor runs in $10,000\text{min}^{-1}$ by applying +1V to pin No. 2.
- In case of making rotation speed $50,000\text{min}^{-1}$, set the maximum rotation speed to $50,000\text{min}^{-1}$ by speed control dial and apply +4V to pin No. 2.

- ⑥ Use alarm signal by pulling signal wire out from pin No. 6 and 7.

Photocoupler output is ON in normal operation and OFF in error condition (negative logic).

<Condition to make photocoupler output OFF>

- In case error occurred
- In case of overheating condition due to increasing temperature inside of this product.
Alarm signal is back to ON condition (normal condition) automatically when temperature inside of this product goes down.
- In case condition that 60mA or less of electric current flows remains for 5 seconds after turning motor on. In this case, alarm signal becomes OFF and load meter turns off at the same time.
- * Alarm signal is by photocoupler output. Be careful to connect because of polarity.
Connect pin No. 6 to positive end and pin No. 7 to negative end.
The maximum voltage between pin No. 6 and 7 is 30V or less. Make electric current 10mA or less.

◎Example of Connection Diagram

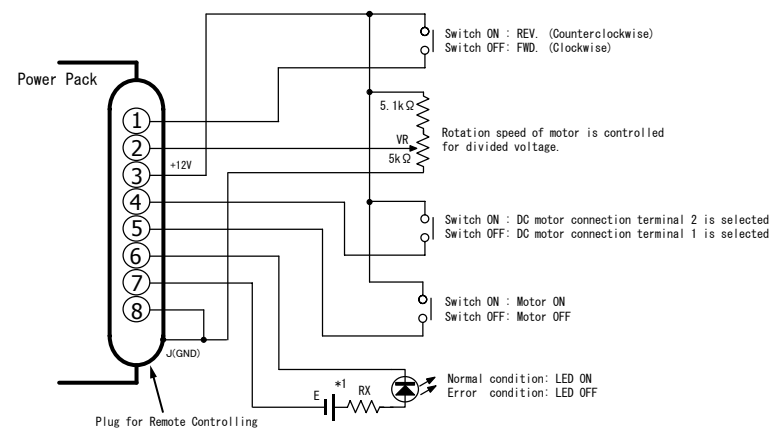

Fig. 13

*1 Make voltage at "E" 30V or less and resistance at "RX" 10mA or less.

e.g. In case of voltage 24V and electric current 5mA: $RX = 24V / 5mA = 4.8k\Omega$ → Use resistance value 4.7kΩ
+12V at pin No. 3 can be used instead of power at "E". In this case, connect ground to J (GND).

7-4 Supplementary Description of External I/O Signal

[Pin No. 1] Rotation Direction Signal

FWD. / REV. can be switched by applying following voltage between pin No. 1 and J (Jack).

Range of control voltage FWD.: 0V - +2V or open

REV.: +6V - +24V (max. voltage: 30V)

Pin No. 1 is used as setting of FS mode as well.

[Pin No. 2] Rotation Speed Signal

Rotation speed can be controlled by applying following voltage between pin No. 2 and J (Jack).

Range of control voltage: +0.4V - +4V (max. voltage +12V)

In spite of applying +4V and more, rotation speed set by speed control dial is the maximum rotation speed.

Rotation speed is changed in accordance with input voltage. Motor runs at minimum rotation speed in case of applying +0.4V or less.

Rotation speed does not exceed rotation speed set by speed control dial in spite of applying voltage +4V and more.

Connect pin No. 2 and 3 (+12V) in case of controlling rotation speed by speed control dial.

[Pin No. 3] +12V power

Can be used as +12V power. Allowable electric current: 50mA or less. Ground is J (Jack).

Do not use for other than external I/O signal of this product.

[Pin No. 4] Switching DC MOTOR Connection Terminal Signal

DC MOTOR 1 and 2 can be switched by applying following voltage between pin No. 4 and J (Jack).

Range of control voltage DC MOTOR 1: 0V - +2V or open

DC MOTOR 2: +6V - + 24V (max. voltage: 30V)

Pin No. 4 is used as setting of VC mode as well.

[Pin No. 5] Signal Turning Motor On / Off

ON / OFF of motor can be switched by applying following voltage between pin No. 5 and J (Jack).

Range of control voltage Motor ON : +6V - +24V (max. voltage: 30V)

Motor OFF: 0V - +1.5V or open

* Turn ON / OFF of motor on 100ms after setting rotation direction and switching DC motor connection terminal.

[Pin No. 6] Alarm Signal (Signal Side)

Pin No. 6 is connected to collector (C) on phototransistor side of photocoupler.

[Pin No. 7] Alarm Signal (Common Side)

Pin No. 7 is connected to emitter (E) on phototransistor side of photocoupler.

Pin No. 6 and 7 are ON (in conducting condition) during normal operation and are OFF (in open condition) in following cases.

○ In case error occurred.

○ In case electric current flowing in motor become 60mA or less while motor runs.

○ In case temperature inside of power pack is high (overheating condition).

[Pin No. 8] Auto Mode Setting Signal

Pin No. 8 and J (Jack) are connected in case of controlling all external I/O signal.

[J (Jack)] GND

Ground of pin No. 3 (+12V) power. J (Jack) is cylindrical metal part of connector.



Caution

- Do not connect pin No. 3 to power prepared by user. May cause of malfunction.
- Connect collector (C) of voltage polarity to positive electrode side and emitter (E) of voltage polarity to negative electrode side between (C) and (E) of alarm signal. Maximum voltage and electric current are as following.

Max. voltage: 30V or less, Max. electric current: 10mA or less

8. Optional Accessory (Refer to product catalog for more information)

Foot Switch (ON / OFF Type) FS202

- ◆ ON / OFF type foot switch.
- Motor is ON while stepping on.



Rubber Cradle

RM11

- ◆ Holder for handpiece.
- Compatible with all handpieces.



Foot Switch (Variable Type) VC302

- ◆ Rotation speed of motor can be controlled corresponding to stepping-on amount.
- Motor stops when removing foot.



Fuse

PFU-2.0A (For C2013 / C2113)

PFU-1.0A (For C2213)



Plug for Remote Controlling RPG-8P

- ◆ Plug compatible with foot switch connection terminal.
- Necessary plug for controlling motor by external signal.



9. Before Asking for Repairing

Condition	Check if	Measure
Power switch does not turn on.	AC power cord is unplugged.	Plug AC power cord.
	Fuse is burnt out.	Replace a fuse designated.
	Power switch is physically broken.	Ask for repairing.
Handpiece does not run.	Straight cord is connected to DC motor connection terminal.	Plug straight cord to DC motor connection terminal.
	Collet chuck on handpiece is in open position.	Close collet chuck.
	Foot switch is connected.	Use foot switch for operation.
	There is any damage and disconnection on straight cord.	Replace straight cord.
Indications of rotation speed and LEVEL (%) switch unintentionally.	Carbon brushes are consumed excessively.	Replace carbon brushes.
	There is any damage and disconnection on straight cord. Indication changes when straight cord is twisted.	Replace straight cord. Ask for repairing.
Countdown is started when turning power switch on.	Handpiece is running already in condition of turning power switch off.	Turn power switch on 10 seconds after confirming handpiece is in stop. Ask for repairing in case countdown continues.

If you still have a trouble after applying measure, malfunction is considered. Ask for repairing. If you have any question or need further assistance, please contact the store you purchased or us.

10. Maintenance

- Check if there is any damage on case, cord, etc.
- Check if dust, oil, water, etc. are stuck.

Inspection and maintenance are regularly needed.

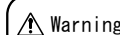

Warning

- May cause of accident and / or malfunction if inspection and maintenance are not provided regularly.